

# OPERATION & MAINTENANCE PLAN

*For*

**Windsor 1 Developers, LLC  
Proposed Wawa Food Market & Fueling Station and Hotel**

**U.S. Route 1 (Brunswick Pike) and Emmons Drive  
Block 7, Lot 59  
Township of West Windsor  
Mercer County, NJ**

Prepared by:



1904 Main Street  
Lake Como, NJ 07719  
(732) 974-0198

A handwritten signature in black ink, appearing to be 'M Sharo', written over a horizontal line.

**Matthew Sharo, PE, PP**  
NJ Professional Engineer License #52989

January 2020  
Last Revised April 2020  
DEC # 1478-99-043

## TABLE OF CONTENTS

	<u>Page</u>
I. INTRODUCTION .....	3
II. RESPONSIBLE PARTIES .....	3
III. STORMWATER CONVEYANCE SYSTEM MAINTENANCE ...	4
IV. MANUFACTURED TREATMENT DEVICE MAINTENANCE .	7
V. GENERAL MAINTENANCE SUMMARY .....	7
VI. APPENDIX	
• Maintenance Work Order & Checklist	
• Maintenance Log	
• Inspection Log	
• First Defense Operation and Maintenance Manual	
• Downstream Defender Operation and Maintenance Manual	

## **I. INTRODUCTION**

The purpose of this report is to provide guidelines and information regarding the maintenance for the existing and proposed stormwater conveyance system in association with the redevelopment of Lot 59, in Block 7 in the Township of West Windsor, Mercer County, New Jersey. The proposed development consists of a 5,585 SF Wawa Food Market with Fueling Station consisting of sixteen (16) filling positions and a 4-story Hyatt Hotel. The proposed development also includes associated parking, driveways, landscaping, lighting, and other related site improvements. The stormwater management system includes a proposed stormwater conveyance system (pipes, inlets, manholes, manufactured treatment devices, etc.). Each facility will require periodic inspections and maintenance.

The stormwater management facilities will contribute toward the safe conveyance and discharge of runoff generated by the proposed development. Every stormwater management system, whether at grade or below grade, requires that basic periodic maintenance to be performed in order to maintain the proper functioning and operation of the system. This report will outline these procedures, further discuss responsibilities, and highlight those responsible for performing said maintenance.

## **II. RESPONSIBLE PARTIES**

<b>Applicant:</b>	Windsor 1 Developers, LLC 1195 Route 70, Suite 2000 Lakewood, NJ 08701 (732) 961-8146
<b>System Owner:</b>	Windsor 1 Developers, LLC 1195 Route 70, Suite 2000 Lakewood, NJ 08701 (732) 961-8146
<b>Township Engineer:</b>	Francis Guzik, PE, CME Township of West Windsor 271 Clarksville Road, PO Box 38 West Windsor, NJ 08550 (609) 799-9396
<b>Design Engineer:</b>	Matthew Sharo, PE, PP Dynamic Engineering Consultants, PC 1904 Main Street Lake Como, NJ 07719 (732) 974-0198

### **III. STORMWATER CONVEYANCE SYSTEM MAINTENANCE**

The stormwater conveyance system has been designed to control and convey stormwater runoff to the proposed discharge point. The stormwater conveyance system includes stormwater inlet hoods and water quality manufactured treatment devices to prevent the outflow of pollutants generated by the proposed development. Without proper routine inspection and maintenance, the system may lose some or all capability to function at full design capacity. Lack of adequate maintenance of the facilities could lead to system failures.

A consulting Professional Engineer should perform regularly scheduled maintenance inspections of the stormwater facilities at least twice each year. The primary purpose of these inspections is to observe and record the operational condition and safety of the facilities. Inspections will also provide information on the effectiveness of regularly scheduled Preventative and Corrective Maintenance Procedures, and will help to identify where changes in the extent and scheduling of the procedures are warranted. The facility inspections should also be used to determine the need for and timing of Corrective Maintenance Procedures.

Routine maintenance of these facilities should be separated into two (2) basic types: Preventative and Corrective Maintenance. Note that a successful maintenance program will emphasize regularly scheduled Preventative Maintenance over emergency-based Corrective Maintenance. Listed below are the Preventative and Corrective Maintenance procedures to be performed on a routine basis:

#### **Preventative Maintenance Procedures:**

The purpose of Preventative Maintenance is to ensure that the system remains operational and safe at all times, while minimizing the need for emergency or corrective maintenance. These procedures are as follows:

##### ***a) Removal and Disposal of Trash and Debris***

All stormwater management components expected to receive and/or trap debris and sediment must be inspected for clogging and excessive debris and sediment accumulation at least four times annually as well as after every storm exceeding one inch of rainfall.

Removal of trash and debris will prevent possible damage to outlets, vegetated areas and eliminate potential mosquito breeding habitats. Disposal of debris and trash must comply with all local, county, state, and federal waste flow control regulations. Only suitable disposal and recycling sites should be utilized.

**b) *Sediment Removal and Disposal***

The stormwater conveyance system should also be evaluated for excessive deposition of sediment. Accumulated sediment should be removed before it threatens the operation of the system. Before de-sedimentation activities are performed, consideration should be given to evacuating all standing water from the system. This may be accomplished by clearing any blocked openings of the structures or by mechanical means such as pumping. If stable soil conditions exist on-site, sediment deposition should not be an excessive maintenance issue. Should a recurrent stabilization situation develop, the inspector should identify the upstream sources of sediment and recommend required stabilization measures.

**c) *Elimination of Potential Mosquito Breeding Habitats***

The most effective mosquito control program is one that eliminates potential breeding habitats. Almost any stagnant pool of water can be attractive to mosquitoes, and may become the source of a large mosquito population. A maintenance program dedicated to eliminating potential breeding areas is preferable to chemical means of controlling mosquitoes. The most important maintenance function is removal of all obstructions to natural flow patterns before stagnant water conditions can develop.

**d) *Parking Lot Maintenance***

This maintenance measure involves employing pavement cleaning practices, such as parking lot sweeping on a regular basis, to minimize pollutant export to the stormwater conveyance system and eventually the receiving waters. These cleaning practices are designed to remove sediment, debris, and other pollutants from access drive and parking lot surfaces that are a potential source of pollution impacting urban waterways. Mechanical machines that use vacuum assisted dry sweeping to remove particulate matter shall be utilized as these have the ability to remove finer sediment particles. Parking lots and access drives shall be swept/vacuumed at least once a month. The disposal of the swept material must be properly hauled off the site and transferred to an approved disposal site.

**Corrective Maintenance Procedures:**

Corrective Maintenance is required on an emergency or non-routine basis to correct problems or malfunctions and to restore the intended operation and safe condition of the conveyance system.

**a) *Removal of Debris and Sediment***

Sediment, debris and trash which threaten the discharge of the conveyance system should be removed immediately and properly disposed. As noted previously, it is recommended that all water be evacuated from the system with a pump before any significant amount of sediment, settled debris or trash is removed from the system. The lack of an available disposal site should not delay the removal of trash, debris and sediment. Temporary disposal sites should be utilized if necessary.

**b) *Structural Repairs***

Structural damage to stormwater conveyance system structures or piping as a result of vandalism, flood events, settlement or other causes must be repaired promptly. The urgency of the repairs will depend upon the nature of the damage and its effects on the safety and operation of the facility. The analysis of structural damage and the design and performance of structural repairs should only be undertaken by the consulting Professional Engineer.

**c) *Extermination of Mosquitoes***

If neglected, the system structures can become an ideal mosquito breeding area. The extermination of mosquitoes will usually require the services of the County Mosquito Commission. If mosquito control in the facility becomes necessary, the preventative maintenance program should be re-evaluated, and more emphasis should be placed on control of mosquito breeding habitats.

**d) *Snow and Ice Removal***

Accumulations of snow and ice can threaten the functioning of the inlet and outlet structures. Provision of the equipment, material and personnel to monitor and remove snow and ice from critical areas will assure the function of the facility during the winter months.

#### **IV. MANUFACTURED TREATMENT DEVICE MAINTENANCE**

The proposed stormwater conveyance system includes two (2) water quality manufactured treatment devices in order to provide treatment to the runoff generated by proposed pavement areas prior to discharge off site. The proposed manufactured treatment devices consist of one (1) First Defense MTD and one (1) Downstream Defender MTD as manufactured by Hydro International. Each manufactured treatment device will provide a treatment rate of 50% TSS removal at each discharge point. Please refer to the First Defense Operation and Maintenance Manual and Downstream Defender Operation and Maintenance Manual in the Appendix of this report for specific details and procedures for maintenance of the manufactured treatment devices.

#### **V. GENERAL MAINTENANCE SUMMARY**

An estimated total cost of approximately **\$8,900.00** will be incurred to maintain the proposed stormwater conveyance system on an annual basis. The following is a summary of the required maintenance tasks and associated costs in written and tabular form:

- Inspections to be performed by a consulting engineer on a bi-annual basis or as needed after a designated storm event. - **\$1,000.00**
- Inspections to be performed by the property owner and/or a maintenance designee on a monthly basis and/or after a storm event exceeding 1 inch of rainfall– **Minimal cost associated – Owners responsibility - \$500.00.**
- Stormwater conveyance system debris removal to be performed on an annual basis and/or as inspection routine dictates - **\$1,000.00.**
- Surface debris removal including garbage and organic matter to be performed in conjunction with lawn and grounds maintenance, includes leave removal in the Fall and removal of excessive amounts of snow, if necessary, in the Winter. These tasks are encouraged as necessary to maintain safe operating conditions (twice a month from Spring through Winter recommended or on as needed basis) - **\$1,000.00.**
- Water quality manufactured treatment device inspection and maintenance to be performed on a bi-annual basis and/or as inspection routine dictates - **\$5,400.00.**

### Maintenance Schedule Summary

<b>Task Identification</b>	<b>Task Frequency</b>	<b>Task Estimated Cost</b>
Inspection by licensed professional consulting engineer	Twice (2) per year	\$1,000.00
Inspection by property owner and/or maintenance designee	Once (1) per month (or after a storm event exceeding 1 inch of rainfall)	\$500.00
Debris removal from stormwater conveyance system (inlets, pipes, and manholes)	Once (1) per year	\$1,000.00
Surface debris removal (garbage & organic matter) including leaves in the Fall and snow in the Winter	Twice (2) per month (or on needed basis)	\$1,000.00
Water quality manufactured treatment device inspection and maintenance	Twice (2) per year	\$5,400.00



# APPENDIX

# **MAINTENANCE WORK ORDER & CHECKLIST**

**MAINTENANCE WORK ORDER AND CHECKLIST  
FOR STORMWATER MANAGEMENT FACILITIES**

NAME OF FACILITY: \_\_\_\_\_ DATE: \_\_\_\_\_  
 LOCATION: \_\_\_\_\_ WORK STARTED: \_\_\_\_\_  
 WEATHER: \_\_\_\_\_ MAINTENANCE PERFORMED BY: \_\_\_\_\_ WORK COMPLETED: \_\_\_\_\_

<b>A. PREVENTATIVE MAINTENANCE</b>				
<b>WORK ITEMS</b>	<b>ITEMS REQUIRED</b>	<b>ITEMS DONE</b>	<b>COMMENTS AND SPECIAL INSTRUCTIONS</b>	
<b>1. GRASS CUTTING</b>				
A. BOTTOMS				
B. EMBANKMENTS AND SIDE SLOPES				
C. PERIMETER AREAS				
D. ACCESS AREAS AND ROADS				
E. OTHERS				
<b>2. GRASS MAINTENANCE</b>				
A. FERTILIZING				
B. RE-SEEDING				
C. DE-THATCHING				
D. PEST CONTROL				
E. OTHERS				
<b>3. VEGETATIVE COVER</b>				
A. FERTILIZING				
B. PRUNING				
C. PEST CONTROL				
D. POISONOUS PLANTS				
E. OTHERS				
<b>4. TRASH AND DEBRIS REMOVAL</b>				
A. BOTTOMS				
B. EMBANKMENTS AND SIDE SLOPES				
C. PERIMETER AREAS				
D. ACCESS AREAS AND ROADS				
E. INLETS				
F. OUTLETS AND TRASH RACKS				
G. OTHERS				
<b>5. SEDIMENT REMOVAL</b>				
A. INLETS				
B. OUTLETS AND TRASH RACKS				
C. LOW FLOW CHANNELS				
D. BOTTOMS				
E. OTHERS				
<b>6. PEST CONTROL</b>				
A. GEESE				
B. MOSQUITO BREEDING				
C. RODENTS / RODENT HOLES				
D. OTHERS				
<b>7. STRUCTURAL REPAIRS</b>				
A. PIPES				
B. FLARED END SECTIONS				
C. INLETS				
D. MANHOLES				
E. OUTLET CONTROL STRUCTURES				
F. LOW FLOW CHANNELS				
G. RIP-RAP				
H. EMERGENCY SPILLWAY				
I. ACCESS AREA / ROADS				
J. FENCE				
K. TRASH RACKS				
L. OTHERS				
<b>8. BASIN REPAIR</b>				
A. EROSION				
B. SAND LAYER REPLACEMENT				
C. HARMFUL POLLUTANT REMOVAL				
D. BASIN LAYER				
E. SNOW / ICE REMOVAL				
F. OTHERS				
<b>9. UNDERGROUND BASIN MAINTENANCE</b>				
A. BOTTOMS				
B. OUTLETS AND TRASH RACKS				
C. ACCESS HATCHES				
D. OTHERS				
<b>10. INFILTRATION BASIN MAINTENANCE</b>				
A. TILING BOTTOM				
<b>11. POND MAINTENANCE</b>				
A. AERATION EQUIPMENT				
B. DEBRIS AND TRASH REMOVAL				
C. WEED REMOVAL				
D. PERMANENT POOL LEVEL				
E. OTHERS				
<b>11. OTHER PREVENTIVE MAINTENANCE</b>				
A. PARKING LOT SWEEPING				
B. EMPTYING TRASH RECEPTACLES				
C. PUMPS AND VALVES				
D. ELECTRICAL PANEL AND WIRING				
E. DEWATERING				
F. GRAFFITI REMOVAL				
E. OTHERS				

B. CORRECTIVE MAINTENANCE			
WORK ITEMS	ITEMS REQUIRED	ITEMS DONE	COMMENTS AND SPECIAL INSTRUCTIONS
1. REMOVAL OF DEBRIS AND SEDIMENT			
2. STRUCTURAL REPAIRS			
3. EMBANKMENTS AND SIDE SLOPES			
4. DEWATERING			
5. BASIN MAINTENANCE			
6. CONTROL OF MOSQUITOES			
7. EROSION REPAIR			
8. FENCE REPAIR			
9. SNOW AND ICE REMOVAL			
10. SAND LAYER REPLACEMENT			
11. OTHER			

C. AESTHETIC MAINTENANCE			
WORK ITEMS	ITEMS REQUIRED	ITEMS DONE	COMMENTS AND SPECIAL INSTRUCTIONS
1. GRAFFITI REMOVAL			
2. GRASS TRIMMING			
3. WEEDING			
4. OTHERS			

GENERAL NOTES AND REMARKS:

MAINTENANCE COMPLETED AND BASED ON ALL AREAS VISIBLE AND ACCESSIBLE AT THE TIME OF INSPECTION.

WORK PERFORMED BY: \_\_\_\_\_

SIGNED: \_\_\_\_\_ DATE: \_\_\_\_\_

# **MAINTENANCE LOG**

**MAINTENANCE LOG  
FOR STORMWATER MANAGEMENT FACILITIES**

NAME OF FACILITY: \_\_\_\_\_  
 LOCATION: \_\_\_\_\_ DATE: \_\_\_\_\_  
 WEATHER: \_\_\_\_\_ WORK STARTED: \_\_\_\_\_  
 MAINTENANCE PERFORMED BY: \_\_\_\_\_ WORK COMPLETED: \_\_\_\_\_

<b>A. PREVENTATIVE MAINTENANCE</b>					
WORK ITEMS	ITEMS REQUIRED	DATE REQUIRED	ITEMS DONE	DATE DONE	COMMENTS AND SPECIAL INSTRUCTIONS
<b>1. GRASS CUTTING</b>					
A. BOTTOMS					
B. EMBANKMENTS AND SIDE SLOPES					
C. PERIMETER AREAS					
D. ACCESS AREAS AND ROADS					
E. OTHERS					
<b>2. GRASS MAINTENANCE</b>					
A. FERTILIZING					
B. RE-SEEDING					
C. DE-THATCHING					
D. PEST CONTROL					
E. OTHERS					
<b>3. VEGETATIVE COVER</b>					
A. FERTILIZING					
B. PRUNING					
C. PEST CONTROL					
D. POISONOUS PLANTS					
E. OTHERS					
<b>4. TRASH AND DEBRIS REMOVAL</b>					
A. BOTTOMS					
B. EMBANKMENTS AND SIDE SLOPES					
C. PERIMETER AREAS					
D. ACCESS AREAS AND ROADS					
E. INLETS					
F. OUTLETS AND TRASH RACKS					
G. OTHERS					
<b>5. SEDIMENT REMOVAL</b>					
A. INLETS					
B. OUTLETS AND TRASH RACKS					
C. LOW FLOW CHANNELS					
D. BOTTOMS					
E. OTHERS					
<b>6. PEST CONTROL</b>					
A. GEESE					
B. MOSQUITO BREEDING					
C. RODENTS / RODENT HOLES					
D. OTHERS					
<b>7. STRUCTURAL REPAIRS</b>					
A. PIPES					
B. FLARED END SECTIONS					
C. INLETS					
D. MANHOLES					
E. OUTLET CONTROL STRUCTURES					
F. LOW FLOW CHANNELS					
G. RIP-RAP					
H. EMERGENCY SPILLWAY					
I. ACCESS AREA / ROADS					
J. FENCE					
K. TRASH RACKS					
L. OTHERS					

8. BASIN REPAIR					
A. EROSION					
B. SAND LAYER REPLACEMENT					
C. HARMFUL POLLUTANT REMOVAL					
D. BASIN LAYER					
E. SNOW / ICE REMOVAL					
F. OTHERS					
9. UNDERGROUND BASIN MAINTENANCE					
A. BOTTOMS					
B. OUTLETS AND TRASH RACKS					
C. ACCESS HATCHES					
D. OTHERS					
10. INFILTRATION BASIN MAINTENANCE					
A. TILING BOTTOM					
11. POND MAINTENANCE					
A. AERATION EQUIPMENT					
B. DEBRIS AND TRASH REMOVAL					
C. WEED REMOVAL					
D. PERMANENT POOL LEVEL					
E. OTHERS					
11. OTHER PREVENTIVE MAINTENANCE					
A. PARKING LOT SWEEPING					
B. EMPTYING TRASH RECEPTACLES					
C. PUMPS AND VALVES					
D. ELECTRICAL PANEL AND WIRING					
E. DEWATERING					
F. GRAFFITI REMOVAL					
E. OTHERS					

B. CORRECTIVE MAINTENANCE					
WORK ITEMS	ITEMS REQUIRED	DATE REQUIRED	ITEMS DONE	DATE DONE	COMMENTS AND SPECIAL INSTRUCTIONS
1. REMOVAL OF DEBRIS AND SEDIMENT					
2. STRUCTURAL REPAIRS					
3. EMBANKMENTS AND SIDE SLOPES					
4. DEWATERING					
5. BASIN MAINTENANCE					
6. CONTROL OF MOSQUITOES					
7. EROSION REPAIR					
8. FENCE REPAIR					
9. SNOW AND ICE REMOVAL					
10. SAND LAYER REPLACEMENT					
11. OTHER					

C. AESTHETIC MAINTENANCE					
WORK ITEMS	ITEMS REQUIRED	DATE REQUIRED	ITEMS DONE	DATE DONE	COMMENTS AND SPECIAL INSTRUCTIONS
1. GRAFFITI REMOVAL					
2. GRASS TRIMMING					
3. WEEDING					
4. OTHERS					

**GENERAL NOTES AND REMARKS:**

MAINTENANCE COMPLETED AND BASED ON ALL AREAS VISIBLE AND ACCESSIBLE AT THE TIME OF INSPECTION.

WORK PERFORMED BY: \_\_\_\_\_

SIGNED: \_\_\_\_\_ DATE: \_\_\_\_\_



# **INSPECTION LOG**

**INSPECTION LOG  
FOR STORMWATER MANAGEMENT FACILITIES**

NAME OF FACILITY: \_\_\_\_\_  
 LOCATION: \_\_\_\_\_ DATE: \_\_\_\_\_  
 WEATHER: \_\_\_\_\_  
 INSPECTION PERFORMED BY: \_\_\_\_\_

<b>A. PREVENTATIVE MAINTENANCE</b>				
FACILITY ITEM	OK (1)	ROUTINE (2)	URGENT (3)	COMMENTS (4)
<b>1. GRASS CUTTING</b>				
A. BOTTOMS				
B. EMBANKMENTS AND SIDE SLOPES				
C. PERIMETER AREAS				
D. ACCESS AREAS AND ROADS				
E. OTHERS				
<b>2. GRASS MAINTENANCE</b>				
A. FERTILIZING				
B. RE-SEEDING				
C. DE-THATCHING				
D. PEST CONTROL				
E. OTHERS				
<b>3. VEGETATIVE COVER</b>				
A. FERTILIZING				
B. PRUNING				
C. PEST CONTROL				
D. POISONOUS PLANTS				
E. OTHERS				
<b>4. TRASH AND DEBRIS REMOVAL</b>				
A. BOTTOMS				
B. EMBANKMENTS AND SIDE SLOPES				
C. PERIMETER AREAS				
D. ACCESS AREAS AND ROADS				
E. INLETS				
F. OUTLETS AND TRASH RACKS				
G. OTHERS				
<b>5. SEDIMENT REMOVAL</b>				
A. INLETS				
B. OUTLETS AND TRASH RACKS				
C. LOW FLOW CHANNELS				
D. BOTTOMS				
E. OTHERS				
<b>6. PEST CONTROL</b>				
A. GEESE				
B. MOSQUITO BREEDING				
C. RODENTS / RODENT HOLES				
D. OTHERS				
<b>7. STRUCTURAL REPAIRS</b>				
A. PIPES				
B. FLARED END SECTIONS				
C. INLETS				
D. MANHOLES				
E. OUTLET CONTROL STRUCTURES				
F. LOW FLOW CHANNELS				
G. RIP-RAP				
H. EMERGENCY SPILLWAY				
I. ACCESS AREA / ROADS				
J. FENCE				
K. TRASH RACKS				
L. OTHERS				
<b>8. BASIN REPAIR</b>				
A. EROSION				
B. SAND LAYER REPLACEMENT				
C. HARMFUL POLLUTANT REMOVAL				
D. BASIN LAYER				
E. SNOW / ICE REMOVAL				
F. OTHERS				

9. UNDERGROUND BASIN MAINTENANCE				
A. BOTTOMS				
B. OUTLETS AND TRASH RACKS				
C. ACCESS HATCHES				
D. OTHERS				
10. INFILTRATION BASIN MAINTENANCE				
A. TILING BOTTOM				
11. POND MAINTENANCE				
A. AERATION EQUIPMENT				
B. DEBRIS AND TRASH REMOVAL				
C. WEED REMOVAL				
D. PERMANENT POOL LEVEL				
E. OTHERS				
11. OTHER PREVENTIVE MAINTENANCE				
A. PARKING LOT SWEEPING				
B. EMPTYING TRASH RECEPTACLES				
C. PUMPS AND VALVES				
D. ELECTRICAL PANEL AND WIRING				
E. DEWATERING				
F. GRAFFITI REMOVAL				
E. OTHERS				

B. CORRECTIVE MAINTENANCE				
FACILITY ITEM	OK (1)	ROUTINE (2)	URGENT (3)	COMMENTS (4)
1. REMOVAL OF DEBRIS AND SEDIMENT				
2. STRUCTURAL REPAIRS				
3. EMBANKMENTS AND SIDE SLOPES				
4. DEWATERING				
5. BASIN MAINTENANCE				
6. CONTROL OF MOSQUITOES				
7. EROSION REPAIR				
8. FENCE REPAIR				
9. SNOW AND ICE REMOVAL				
10. SAND LAYER REPLACEMENT				
11. OTHER				

C. AESTHETIC MAINTENANCE				
FACILITY ITEM	OK (1)	ROUTINE (2)	URGENT (3)	COMMENTS (4)
1. GRAFFITI REMOVAL				
2. GRASS TRIMMING				
3. WEEDING				
4. OTHERS				

REMARKS

- (1) ITEM CHECKED IS IN GOOD CONDITION, AND THE MAINTENANCE PROGRAM IS ADEQUATE.
- (2) ITEM CHECKED REQUIRES ATTENTION, BUT DOES NOT PRESENT AN IMMEDIATE THREAT TO THE FACILITY FUNCTION OR OTHER FACILITY COMPONENTS.
- (3) THE ITEM CHECKED REQUIRES IMMEDIATE ATTENTION TO KEEP THE FACILITY OPERATIONAL OR TO PREVENT DAMAGE TO OTHER FACILITY COMPONENTS.
- (4) PROVIDE EXPLANATION AND DETAILS IF COLUMNS 2 OR 3 ARE CHECKED.

**GENERAL NOTES AND REMARKS:**

INSPECTION COMPLETED AND BASED ON ALL AREAS VISIBLE AND ACCESSIBLE AT THE TIME OF INSPECTION.

WORK PERFORMED BY: \_\_\_\_\_

SIGNED: \_\_\_\_\_ DATE: \_\_\_\_\_

**FIRST DEFENSE OPERATION AND MAINTENANCE  
MANUAL**



## Table of Contents

3	<b>FIRST DEFENSE® BY HYDRO INTERNATIONAL</b>
	- INTRODUCTION
	- OPERATION
	- POLLUTANT CAPTURE AND RETENTION
4	<b>MODEL SIZES &amp; CONFIGURATIONS</b>
	- FIRST DEFENSE® COMPONENTS
5	<b>MAINTENANCE</b>
	- OVERVIEW
	- MAINTENANCE EQUIPMENT CONSIDERATIONS
	- DETERMINING YOUR MAINTENANCE SCHEDULE
6	<b>MAINTENANCE PROCEDURES</b>
	- INSPECTION
	- FLOATABLES AND SEDIMENT CLEAN OUT
8	<b>FIRST DEFENSE® INSTALLATION LOG</b>
9	<b>FIRST DEFENSE® INSPECTION AND MAINTENANCE LOG</b>

**COPYRIGHT STATEMENT:** The contents of this manual, including the graphics contained herein, are intended for the use of the recipient to whom the document and all associated information are directed. Hydro International plc owns the copyright of this document, which is supplied in confidence. It must not be used for any purpose other than that for which it is supplied and must not be reproduced, in whole or in part stored in a retrieval system or transmitted in any form or by any means without prior permission in writing from Hydro International plc. First Defense® is a trademarked hydrodynamic vortex separation device of Hydro International plc. A patent covering the First Defense® has been granted.

**DISCLAIMER:** Information and data contained in this manual is exclusively for the purpose of assisting in the operation and maintenance of Hydro International plc's First Defense®. No warranty is given nor can liability be accepted for use of this information for any other purpose. Hydro International plc has a policy of continuous product development and reserves the right to amend specifications without notice.

## I. First Defense® by Hydro International

### Introduction

The First Defense® is an enhanced vortex separator that combines an effective and economical stormwater treatment chamber with an integral peak flow bypass. It efficiently removes total suspended solids (TSS), trash and hydrocarbons from stormwater runoff without washing out previously captured pollutants. The First Defense® is available in several model configurations (refer to *Section II. Model Sizes & Configurations*, page 4) to accommodate a wide range of pipe sizes, peak flows and depth constraints.

### Operation

The First Defense® operates on simple fluid hydraulics. It is self-activating, has no moving parts, no external power requirement and is fabricated with durable non-corrosive components. No manual procedures are required to operate the unit and maintenance is limited to monitoring accumulations of stored pollutants and periodic clean-outs. The First Defense® has been designed to allow for easy and safe access for inspection, monitoring and clean-out procedures. Neither entry into the unit nor removal of the internal components is necessary for maintenance, thus safety concerns related to confined-space-entry are avoided.

### Pollutant Capture and Retention

The internal components of the First Defense® have been designed to optimize pollutant capture. Sediment is captured and retained in the base of the unit, while oil and floatables are stored on the water surface in the inner volume (Fig.1).

The pollutant storage volumes are isolated from the built-in bypass chamber to prevent washout during high-flow storm events. The sump of the First Defense® retains a standing water level between storm events. This ensures a quiescent flow regime at the onset of a storm, preventing resuspension and washout of pollutants captured during previous events.

Accessories such as oil absorbent pads are available for enhanced oil removal and storage. Due to the separation of the oil and floatable storage volume from the outlet, the potential for washout of stored pollutants between clean-outs is minimized.

### Applications

- Stormwater treatment at the point of entry into the drainage line
- Sites constrained by space, topography or drainage profiles with limited slope and depth of cover
- Retrofit installations where stormwater treatment is placed on or tied into an existing storm drain line
- Pretreatment for filters, infiltration and storage

### Advantages

- Inlet options include surface grate or multiple inlet pipes
- Integral high capacity bypass conveys large peak flows without the need for "offline" arrangements using separate junction manholes
- Proven to prevent pollutant washout at up to 500% of its treatment flow
- Long flow path through the device ensures a long residence time within the treatment chamber, enhancing pollutant settling
- Delivered to site pre-assembled and ready for installation

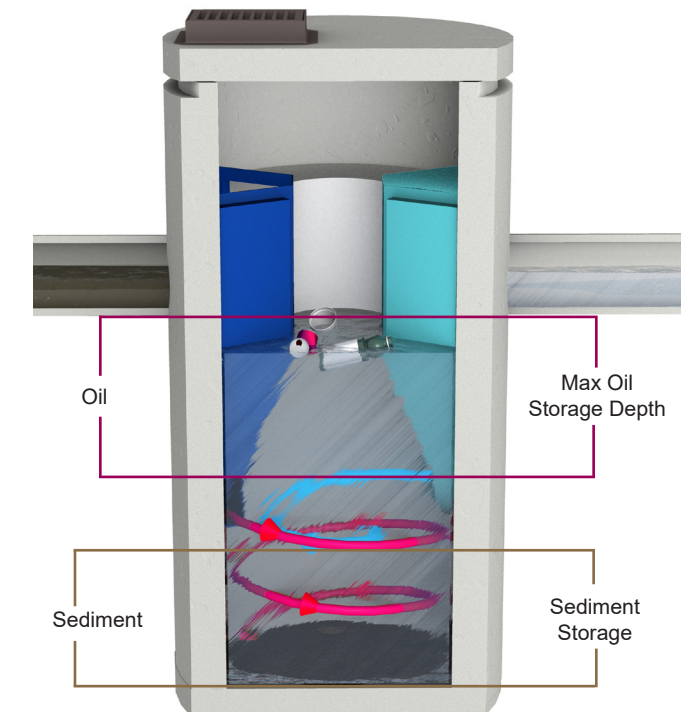

Fig.1 Pollutant storage volumes in the First Defense®.

## II. Model Sizes & Configurations

The First Defense® inlet and internal bypass arrangements are available in several model sizes and configurations. The components of the First Defense®-4HC and First Defense®-6HC have modified geometries as to allow greater design flexibility needed to accommodate various site constraints.

All First Defense® models include the internal components that are designed to remove and retain total suspended solids (TSS), gross solids, floatable trash and hydrocarbons (Fig.2a - 2b). First Defense® model parameters and design criteria are shown in Table 1.

### First Defense® Components

1. Built-In Bypass
2. Inlet Pipe
3. Inlet Chute
4. Floatables Draw-off Port
5. Outlet Pipe
6. Floatables Storage
7. Sediment Storage
8. Inlet Grate or Cover

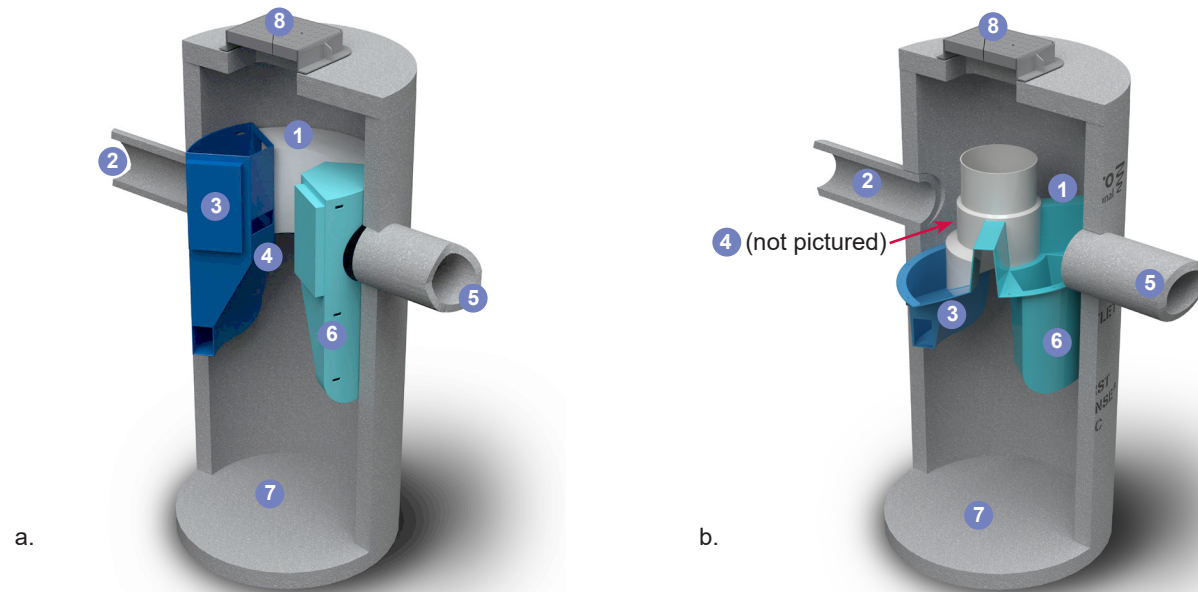

Fig.2a) First Defense®-4 and First Defense®-6; b) First Defense®-4HC and First Defense®-6HC, with higher capacity dual internal bypass and larger maximum pipe diameter.

First Defense® High Capacity Model Number	Diameter	Typical TSS Treatment Flow Rates	Peak Online Flow Rate	Maximum Pipe Diameter <sup>1</sup>	Oil Storage Capacity	Typical Sediment Storage Capacity <sup>2</sup>	Minimum Distance from Outlet Invert to Top of Rim <sup>3</sup>	Chamber Depth
		NJDEP Certified						
	(ft / m)	(cfs / L/s)	(cfs / L/s)	(in / mm)	(gal / L)	(yd <sup>3</sup> / m <sup>3</sup> )	(ft / m)	(ft / m)
FD-3HC	3 / 0.9	0.85 / 24.0	15 / 424	18 / 457	125 / 473	0.4 / 0.3	2.0 - 3.5 / 0.6 - 1.0	3.75 / 1.14
FD-4HC	4 / 1.2	1.50 / 42.4	18 / 510	24 / 600	191 / 723	0.7 / 0.5	2.3 - 3.9 / 0.7 - 1.2	5.00 / 1.52
FD-5HC	5 / 1.5	2.35 / 66.2	20 / 566	24 / 609	300 / 1135	1.1 / .84	2.5 - 4.5 / 0.7 - 1.3	5.25 / 1.60
FD-6HC	6 / 1.8	3.38 / 95.7	32 / 906	30 / 750	496 / 1878	1.6 / 1.2	3.0 - 5.1 / 0.9 - 1.6	6.25 / 1.90
FD-7HC	7 / 2.1	4.60 / 130.2	40 / 1133	42 / 1067	750 / 2839	2.1 / 1.9	3.0 - 5.5 / 0.9 - 1.7	7.25 / 2.20
FD-8HC	8 / 2.4	6.00 / 169.9	50 / 1,415	48 / 1219	1120 / 4239	2.8 / 2.1	3.0 - 6.0 / 0.9 - 1.8	8.00 / 2.43

<sup>1</sup>Contact Hydro International when larger pipe sizes are required.  
<sup>2</sup>Contact Hydro International when custom sediment storage capacity is required.  
<sup>3</sup>Minimum distance for models depends on pipe diameter.

## III. Maintenance

### Overview

The First Defense® protects the environment by removing a wide range of pollutants from stormwater runoff. Periodic removal of these captured pollutants is essential to the continuous, long-term functioning of the First Defense®. The First Defense® will capture and retain sediment and oil until the sediment and oil storage volumes are full to capacity. When sediment and oil storage capacities are reached, the First Defense® will no longer be able to store removed sediment and oil. Maximum pollutant storage capacities are provided in Table 1.

The First Defense® allows for easy and safe inspection, monitoring and clean-out procedures. A commercially or municipally owned sump-vac is used to remove captured sediment and floatables. Access ports are located in the top of the manhole.

Maintenance events may include Inspection, Oil & Floatables Removal, and Sediment Removal. Maintenance events do not require entry into the First Defense®, nor do they require the internal components of the First Defense® to be removed. In the case of inspection and floatables removal, a vactor truck is not required. However, a vactor truck is required if the maintenance event is to include oil removal and/or sediment removal.

### Maintenance Equipment Considerations

The internal components of the First Defense®-HC have a centrally located circular shaft through which the sediment storage sump can be accessed with a sump vac hose. The open diameter of this access shaft is 15 inches in diameter (Fig.3). Therefore, the nozzle fitting of any vactor hose used for maintenance should be less than 15 inches in diameter.

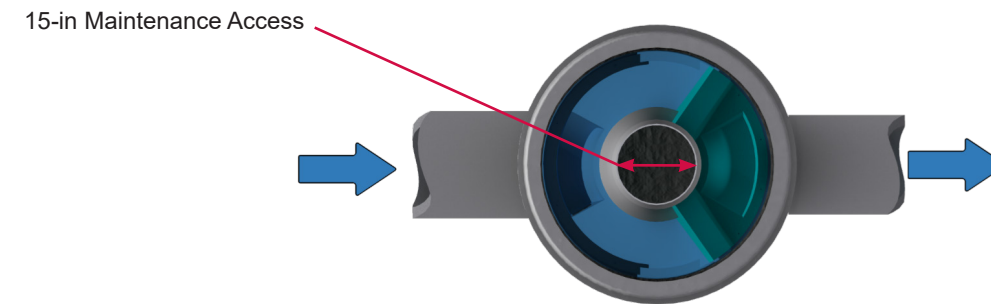

Fig.3 The central opening to the sump of the First Defense®-HC is 15 inches in diameter.

### Determining Your Maintenance Schedule

The frequency of clean out is determined in the field after installation. During the first year of operation, the unit should be inspected every six months to determine the rate of sediment and floatables accumulation. A simple probe such as a Sludge-Judge® can be used to determine the level of accumulated solids stored in the sump. This information can be recorded in the maintenance log (see page 9) to establish a routine maintenance schedule.

The vactor procedure, including both sediment and oil / floatables removal, for a 6-ft First Defense® typically takes less than 30 minutes and removes a combined water/oil volume of about 765 gallons.



**Inspection Procedures**

1. Set up any necessary safety equipment around the access port or grate of the First Defense® as stipulated by local ordinances. Safety equipment should notify passing pedestrian and road traffic that work is being done.
2. Remove the grate or lid to the manhole.
3. Without entering the vessel, look down into the chamber to inspect the inside. Make note of any irregularities. Fig.4 shows the standing water level that should be observed.
4. Without entering the vessel, use the pole with the skimmer net to remove floatables and loose debris from the components and water surface.
5. Using a sediment probe such as a Sludge Judge®, measure the depth of sediment that has collected in the sump of the vessel.
6. On the Maintenance Log (see page 9), record the date, unit location, estimated volume of floatables and gross debris removed, and the depth of sediment measured. Also note any apparent irregularities such as damaged components or blockages.
7. Securely replace the grate or lid.
8. Take down safety equipment.
9. Notify Hydro International of any irregularities noted during inspection.

**Floatables and Sediment Clean Out**

Floatables clean out is typically done in conjunction with sediment removal. A commercially or municipally owned sump-vac is used to remove captured sediment and floatables (Fig.5).

Floatables and loose debris can also be netted with a skimmer and pole. The access port located at the top of the manhole provides unobstructed access for a vactor hose and skimmer pole to be lowered to the base of the sump.

**Scheduling**

- Floatables and sump clean out are typically conducted once a year during any season.
- Floatables and sump clean out should occur as soon as possible following a spill in the contributing drainage area.



Fig.4 Floatables are removed with a vactor hose (First Defense model FD-4, shown).

**Recommended Equipment**

- Safety Equipment (traffic cones, etc)
- Crow bar or other tool to remove grate or lid
- Pole with skimmer or net (if only floatables are being removed)
- Sediment probe (such as a Sludge Judge®)
- Vactor truck (flexible hose recommended)
- First Defense® Maintenance Log

**Floatables and sediment Clean Out Procedures**

1. Set up any necessary safety equipment around the access port or grate of the First Defense® as stipulated by local ordinances. Safety equipment should notify passing pedestrian and road traffic that work is being done.
2. Remove the grate or lid to the manhole.
3. Without entering the vessel, look down into the chamber to inspect the inside. Make note of any irregularities.
4. Remove oil and floatables stored on the surface of the water with the vactor hose (Fig.5) or with the skimmer or net (not pictured).
5. Using a sediment probe such as a Sludge Judge®, measure the depth of sediment that has collected in the sump of the vessel and record it in the Maintenance Log (page 9).
6. Once all floatables have been removed, drop the vactor hose to the base of the sump. Vactor out the sediment and gross debris off the sump floor (Fig.5).
7. Retract the vactor hose from the vessel.
8. On the Maintenance Log provided by Hydro International, record the date, unit location, estimated volume of floatables and gross debris removed, and the depth of sediment measured. Also note any apparent irregularities such as damaged components, blockages, or irregularly high or low water levels.
9. Securely replace the grate or lid.



Fig.5 Sediment is removed with a vactor hose (First Defense model FD-4, shown).

**Maintenance at a Glance**

Inspection	- Regularly during first year of installation - Every 6 months after the first year of installation
Oil and Floatables Removal	- Once per year, with sediment removal - Following a spill in the drainage area
Sediment Removal	- Once per year or as needed - Following a spill in the drainage area

NOTE: For most clean outs the entire volume of liquid does not need to be removed from the manhole. Only remove the first few inches of oils and floatables from the water surface to reduce the total volume of liquid removed during a clean out.





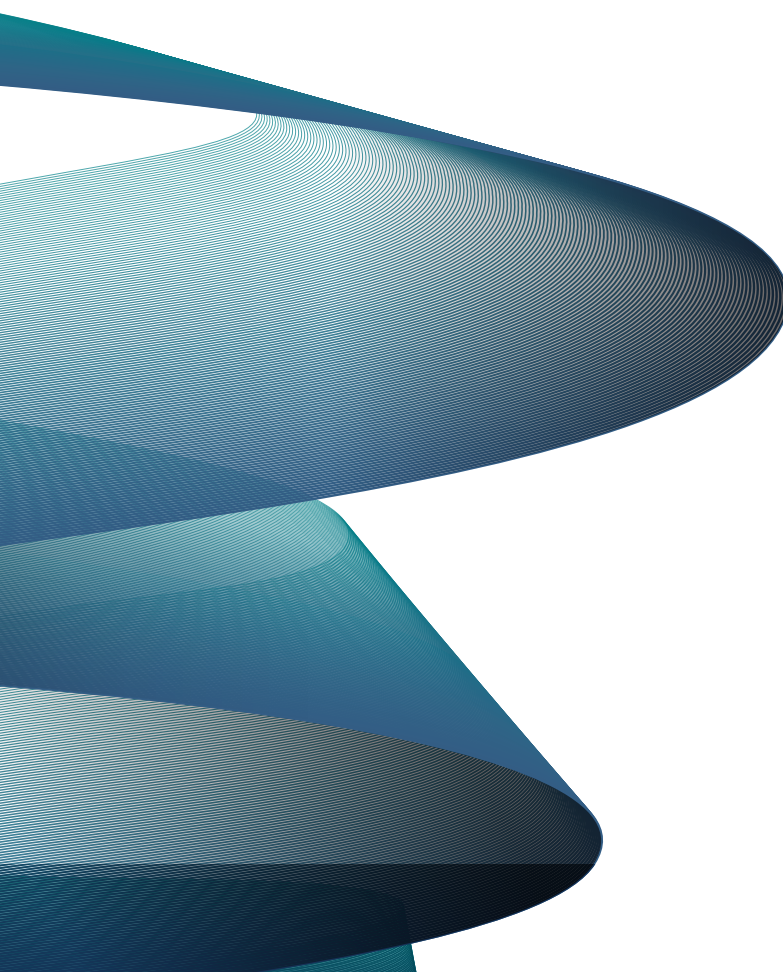

## Stormwater Solutions

94 Hutchins Drive  
Portland, ME 04102

Tel: (207) 756-6200

Fax: (207) 756-6212

[stormwaterinquiry@hydro-int.com](mailto:stormwaterinquiry@hydro-int.com)

[www.hydro-int.com](http://www.hydro-int.com)

**DOWNSTREAM DEFENDER OPERATION AND  
MAINTENANCE MANUAL**

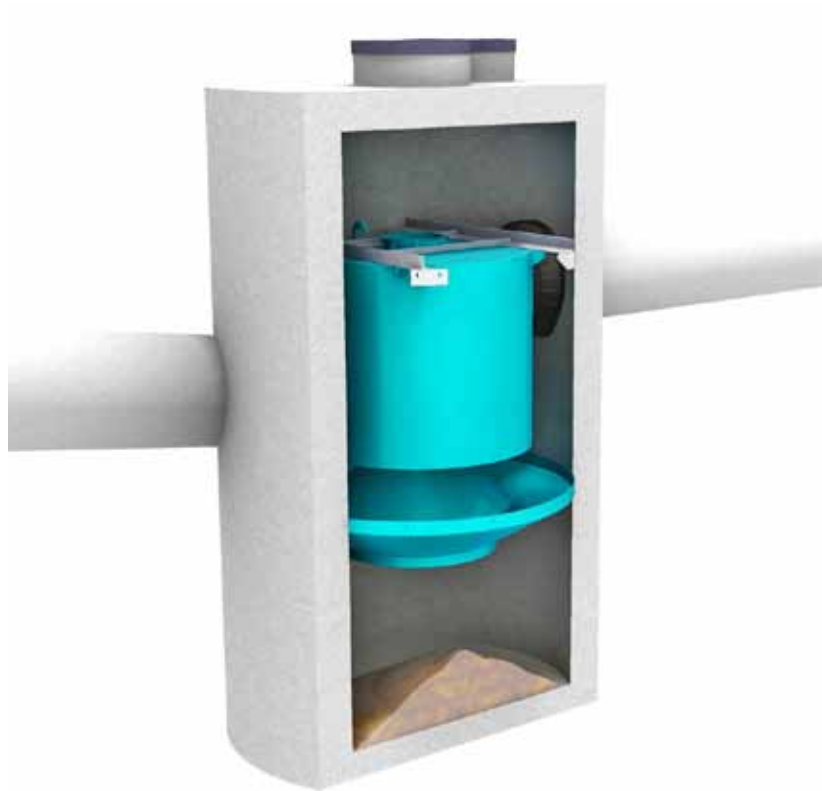

## Operation and Maintenance Manual

**Downstream Defender<sup>®</sup>**

---

Vortex Separator for Stormwater Treatment

Stormwater Solutions  
Turning Water Around ...<sup>®</sup>



## Table of Contents

<b>3</b>	<b>Downstream Defender® by Hydro International</b> <ul style="list-style-type: none"><li>- Benefits of the Downstream Defender®</li><li>- Applications</li><li>- Downstream Defender® Components</li></ul>
<b>4</b>	<b>Operation</b> <ul style="list-style-type: none"><li>- Introduction</li><li>- Pollutant Capture and Retention</li><li>- Wet Sump</li><li>- Blockage Protection</li></ul>
<b>4</b>	<b>Maintenance</b> <ul style="list-style-type: none"><li>- Overview</li><li>- Determining Your Maintenance Schedule</li></ul>
<b>5</b>	<b>Maintenance Procedures</b> <ul style="list-style-type: none"><li>- Inspection</li><li>- Floatables and Sediment Cleanout</li></ul>
<b>8</b>	<b>Downstream Defender® Installation Log</b>
<b>9</b>	<b>Downstream Defender® Inspection Log</b>
<b>10</b>	<b>Downstream Defender® Maintenance Log</b>

---

**COPYRIGHT STATEMENT:** The contents of this manual, including the drawings and specifications contained herein or annexed hereto, are intended for the use of the recipient to whom the document and all associated information are directed. Hydro International plc owns the copyright of this document (including any drawings or graphics), which is supplied in confidence. It must not be used for any purpose other than that for which it is supplied and must not be reproduced, in whole or in part stored in a retrieval system or transmitted in any form or by any means without prior permission in writing from Hydro International plc. Downstream Defender® is a trademarked hydrodynamic vortex separation device of Hydro International plc. A patent covering the Downstream Defender® has been granted.

**DISCLAIMER:** Information and data contained in this manual is exclusively for the purpose of assisting in the operation and maintenance of Hydro International plc's Downstream Defender®. No warranty is given nor can liability be accepted for use of this information for any other purpose. Hydro International plc have a policy of continuous product development and reserve the right to amend specifications without notice.

# Downstream Defender® by Hydro International

The Downstream Defender® is an advanced Hydrodynamic Vortex Separator designed to provide high removal efficiencies of settleable solids and their associated pollutants, oil, and floatables over a wide range of flow rates.

The Downstream Defender® has unique, flow-modifying internal components developed from extensive full-scale testing, CFD modeling and over thirty years of hydrodynamic separation experience in wastewater, combined sewer and stormwater applications. These internal components distinguish the Downstream Defender® from simple swirl-type devices and conventional oil/grit separators by minimizing turbulence and headlosses, enhancing separation, and preventing washout of previously stored pollutants.

The high removal efficiencies and inherent low headlosses of the Downstream Defender® allow for a small footprint making it a compact and economical solution for the treatment of non-point source pollution.

See page 12 for more about Hydro International's Stormwater BMP Maintenance Contractor Certification Program.

## Benefits of the Downstream Defender®

- Removes sediment, floatables, oil and grease
- No pollutant washouts
- Small footprint
- No loss of treatment capacity between clean-outs
- Low headloss
- Efficient over a wide range of flows
- Easy to install
- Low maintenance

## Applications

- New developments and retrofits
- Utility yards
- Streets and roadways
- Parking lots
- Pre-treatment for filters, infiltration and storage
- Industrial and commercial facilities
- Wetlands protection
- Pretreatment to Low Impact Development practices

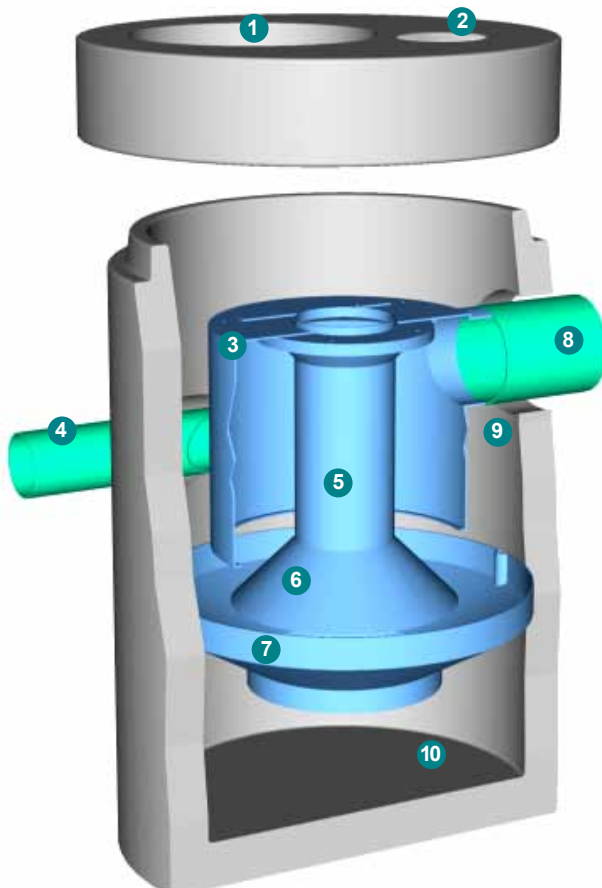

## Downstream Defender® Components

1. Central Access Port (all models)
2. Floatables Access Port (6-ft/1.8m, 8-ft/2.4m, 10-ft/3.0m and 12-ft/3.7m models only)
3. Dip Plate with Integral Floatables Lid
4. Tangential Inlet
5. Center Shaft
6. Center Cone
7. Benching Skirt
8. Outlet Pipe
9. Floatables Storage Zone
10. Isolated Sediment Storage Zone

Fig. 1 Components of the Downstream Defender®.





## Operation

### Introduction

The Downstream Defender® operates on simple fluid hydraulics. It is self-activating, has no moving parts, no external power requirement and is manufactured from durable non-corrosive components. No manual procedures are required to operate the unit and maintenance is limited to monitoring accumulations of stored pollutants and periodic clean-outs. The Downstream Defender® has been designed to allow for easy and safe access for inspection/monitoring and clean-out procedures. Entry into the unit or removal of the internal components is not necessary for maintenance, thus safety concerns related to confined-space-entry are avoided.

### Pollutant Capture and Retention

The internal components of the Downstream Defender® have been designed to protect the oil/floatables and sediment storage volumes so that separator performance is not reduced as pollutants accumulate between clean-outs (Fig.2). The Downstream Defender® vessel remains wet between storm events. Oil and floatables are stored on the water surface in the outer annulus separate from the sediment storage volume in the sump of the unit providing the option for separate oil disposal, and accessories such as adsorbant pads. Since the oil/floatables and sediment storage volumes are isolated from the active separation region, the potential for re-suspension and washout of stored pollutants between clean-outs is minimized.

### Wet Sump

The sump of the Downstream Defender® retains a standing water

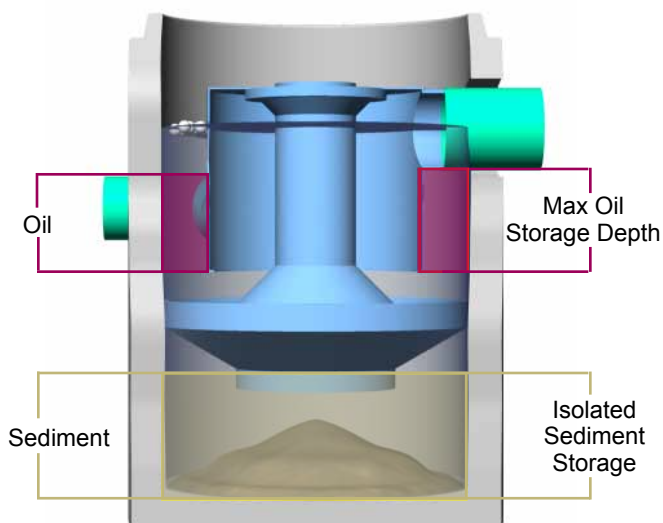

Fig.2 Pollutant storage volumes of the Downstream Defender®.

level between storm events. The water in the sump prevents stored sediment from solidifying in the base of the unit. (The clean-out procedure becomes more difficult and labor intensive if the system allows fine sediment to dry-out and consolidate. Dried sediment must be manually removed by maintenance crews. This is a labor intensive operation in a hazardous environment.)

### Blockage Protection

The Downstream Defender® has large clear openings and no internal restrictions or weirs, minimizing the risk of blockage and hydraulic losses. In addition to increasing the system headloss, orifices and internal weirs can increase the risk of blockage within the unit.

## Maintenance

### Overview

The Downstream Defender® protects the environment by removing a wide range of pollutants from stormwater runoff. Periodic removal of these captured pollutants is essential to the continuous, long-term functioning of the Downstream Defender®. The Downstream Defender® will capture and retain sediment and oil until the sediment and oil storage volumes are full to capacity. When sediment and oil storage capacities are reached, the Downstream Defender® will no longer be able to store removed sediment and oil. Maximum pollutant storage capacities are provided in Table 1.

Hydro International recommends that maintenance crews watch the Downstream Defender® maintenance training video at [www.hydro-int.com/us/products/downstream-defender](http://www.hydro-int.com/us/products/downstream-defender). Maintenance providers are also encouraged to participate in Hydro International's Maintenance Contractor Certification Program (see page 12).



Fig.3 Watch the Downstream Defender® instructional maintenance video at [www.hydro-int.com/us/products/downstream-defender](http://www.hydro-int.com/us/products/downstream-defender).

The Downstream Defender® allows for easy and safe inspection, monitoring and clean-out procedures. A commercially or municipally owned sump-vac is used to remove captured sediment and floatables. Access ports are located in the top of the manhole. On the 6-ft (1.8m), 8-ft (2.4m), 10-ft (3.0m) and 12-ft (3.7m) units, the floatables access port is above the outlet pipe between the concrete manhole wall and the dip plate. The sediment removal access ports for all Downstream Defender® models are located directly over the hollow center shaft.

Maintenance events may include Inspection, Oil & Floatables Removal, and Sediment Removal. Maintenance events do not require entry into the Downstream Defender®, nor do they require the internal components of the Downstream Defender® to be removed. In the case of inspection and floatables removal, a vactor truck is not required. However, a vactor truck is required if the maintenance event is to include oil removal and/or sediment removal.

### Determining Your Maintenance Schedule

The frequency of cleanout is determined in the field after installation. During the first year of operation, the unit should be inspected every six months to determine the rate of sediment and floatables accumulation. A simple probe such as a Sludge Judge® can be used to determine the level of accumulated solids stored in the sump. This information can be recorded in the maintenance log (see page 9) to establish a routine maintenance schedule.

The vactor procedure, including both sediment and oil/floatables removal, for a 6-ft (1.8m) Downstream Defender® typically takes less than 30 minutes and removes a combined water/oil volume of about 500 gallons (1900 liters).

### Inspection Procedures

Inspection is a simple process that does not involve entry into the Downstream Defender®. Maintenance crews should be familiar with the Downstream Defender® and its components prior to inspection.

### Scheduling

- It is important to inspect your Downstream Defender® every six months during the first year of operation to determine your site-specific rate of pollutant accumulation
- Typically, inspection may be conducted during any season of the year
- Sediment removal is not required unless sediment depths exceed 75% of maximum clean-out depths stated in Table 1

### Recommended Equipment

- Safety Equipment and Personal Protective Equipment (traffic cones, work gloves, etc.)
- Crow bar or other tool to remove grate or lid
- Pole with skimmer or net
- Sediment probe (such as a Sludge Judge®)
- Trash bag for removed floatables
- Downstream Defender® Maintenance Log

Table 1. Downstream Defender® Pollutant Storage Capacities and Max. Cleanout Depths.

Unit Diameter		Total Oil Storage		Oil Clean-out Depth		Total Sediment Storage		Sediment Clean-out Depth		Max. Liquid Volume Removed	
(ft)	(m)	(gal)	(L)	(in)	(cm)	(yd <sup>3</sup> )	(m <sup>3</sup> )	(in)	(cm)	(gal)	(L)
4	1.2	70	265	<16	<41	0.70	0.53	<18	<45	384	1,454
6	1.8	216	818	<23	<58	2.10	1.61	<24	<61	1,239	4,690
8	2.4	540	2,044	<33	<84	4.65	3.56	<30	<76	2,884	10,917
10	3.0	1,050	3,975	<42	<107	8.70	6.65	<36	<91	5,546	20,994
12	3.7	1,770	6,700	<49	<125	14.70	11.24	<42	<107	9,460	35,810

### NOTES

1. Refer to Downstream Defender® Clean-out Detail (Fig.2) for measurement of depths.
2. Oil accumulation is typically less than sediment, however, removal of oil and sediment during the same service is recommended.
3. Remove floatables first, then remove sediment storage volume.
4. Sediment removal is not required unless sediment depths exceed 75% of maximum clean-out depths stated in Table 1.





Fig. 4



Fig. 5



Fig. 6

### Inspection Procedures

1. Set up any necessary safety equipment around the access port or grate of the Downstream Defender® as stipulated by local ordinances. Safety equipment should notify passing pedestrian and road traffic that work is being done.
2. Remove the lids to the manhole (Fig. 4). NOTE: The 4-ft (1.2m) Downstream Defender® will only have one lid.
3. Without entering the vessel, look down into the chamber to inspect the inside. Make note of any irregularities. See Fig. 7 and 8 for typical inspection views.
4. Without entering the vessel, use the pole with the skimmer net to remove floatables and loose debris from the outer annulus of the chamber.
5. Using a sediment probe such as a Sludge Judge®, measure the depth of sediment that has collected in the sump of the vessel (Fig. 5).
6. On the Maintenance Log (see page 9), record the date, unit location, estimated volume of floatables and gross debris removed, and the depth of sediment measured. Also note any apparent irregularities such as damaged components or blockages.



Fig. 7 View over center shaft into sediment storage zone.



Fig. 8 View of outer annulus of floatables and oil collection zone.

7. Securely replace the grate or lid.
8. Take down safety equipment.
9. Notify Hydro International of any irregularities noted during inspection.

### Floatables and Sediment Cleanout

Floatables cleanout is typically done in conjunction with sediment removal. A commercially or municipally owned sump-vac is used to remove captured sediment and floatables (Fig. 6).

Floatables and loose debris can also be netted with a skimmer and pole. The access port located at the top of the manhole provides unobstructed access for a vacator hose and skimmer pole to be lowered to the base of the sump.

### Scheduling

- Floatables and sump cleanout are typically conducted once a year during any season.
- If sediment depths are greater than 75% of maximum cleanout depths stated in Table 1, sediment removal is required.
- Floatables and sump cleanout should occur as soon as possible following a spill in the contributing drainage area.



**Recommended Equipment**

- Safety Equipment (traffic cones, etc)
- Crow bar or other tool to remove grate or lid
- Pole with skimmer or net (if only floatables are being removed)
- Sediment probe (such as a Sludge Judge®)
- Vactor truck (6-inch/150mm diameter flexible hose recommended)
- Downstream Defender® Maintenance Log

**Floatables and Sediment Clean Out Procedures**

1. Set up any necessary safety equipment around the access port or grate of the Downstream Defender® as stipulated by local ordinances. Safety equipment should notify passing pedestrian and road traffic that work is being done.
2. Remove the lids to the manhole NOTE: The 4-ft (1.2m) Downstream Defender® will only have one lid.
3. Without entering the vessel, look down into the chamber to inspect the inside. Make note of any irregularities.
4. Using the Floatables Port for access, remove oil and floatables stored on the surface of the water with the vactor hose or the skimmer net (Fig.9, top).
5. Using a sediment probe such as a Sludge Judge®, measure the depth of sediment that has collected in the sump of the vessel and record it in the Maintenance Log (Pg.9).
6. Once all floatables have been removed, drop the vactor hose to the base of the sump via the Central Access Port. Vactor out the sediment and gross debris off the sump floor (Fig.6 and 9).

7. Retract the vactor hose from the vessel.
8. On the Maintenance Log provided by Hydro International, record the date, unit location, estimated volume of floatables and gross debris removed, and the depth of sediment measured. Also note any apparent irregularities such as damaged components or blockages.
9. Securely replace the grate or lid.

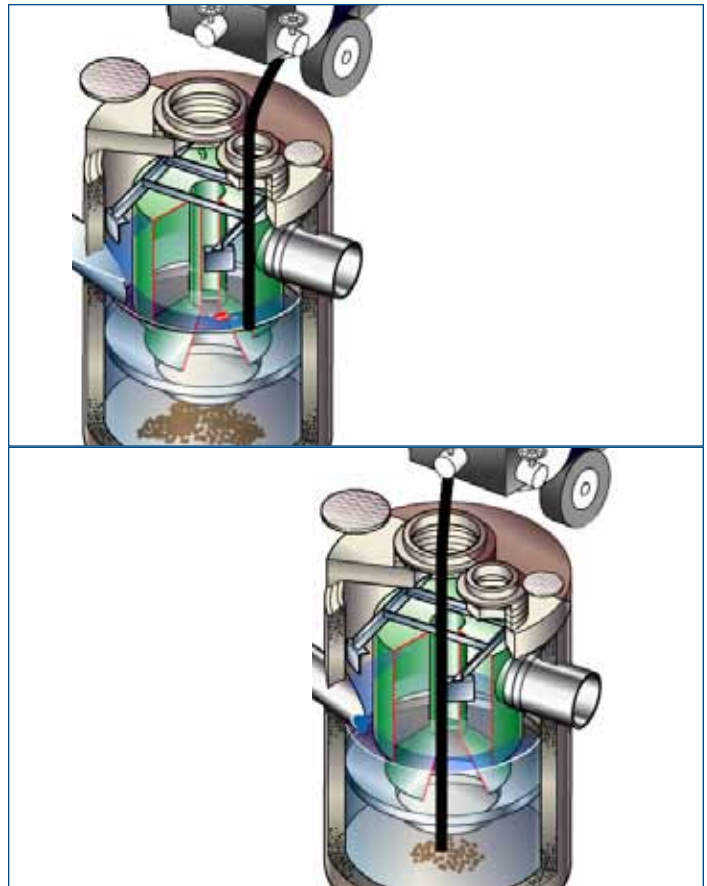

Fig.9 Floatables and sediment are removed with a vactor hose

**Maintenance at a Glance**

Activity	Frequency
Inspection	- Regularly during first year of installation - Every 6 months after the first year of installation
Oil and Floatables Removal	- Once per year, with sediment removal - Following a spill in the drainage area
Sediment Removal	- Once per year or as needed - Following a spill in the drainage area

NOTE: For most cleanouts it is not necessary to remove the entire volume of liquid in the vessel. Only removing the first few inches of oils/floatables and the sediment storage volume is required.



## Downstream Defender® Installation Log

HYDRO INTERNATIONAL REFERENCE NUMBER:	
SITE NAME:	
SITE LOCATION:	
OWNER:	CONTRACTOR:
CONTACT NAME:	CONTACT NAME:
COMPANY NAME:	COMPANY NAME:
ADDRESS:	ADDRESS:
TELEPHONE:	TELEPHONE:
FAX:	FAX:

INSTALLATION DATE:    /    /

MODEL (CIRCLE ONE):      4-FT      6-FT      8-FT      10-FT      12-FT  
    (1.2m)      (1.8m)      (2.4m)      (3m)      (3.7m)



## Downstream Defender® Maintenance Log

Site Name: \_\_\_\_\_ Owner Change since last inspection? Y N

Location: \_\_\_\_\_

Owner Name: \_\_\_\_\_

Address: \_\_\_\_\_ Phone Number: \_\_\_\_\_

Site Status: \_\_\_\_\_

Date: \_\_\_\_\_ Time: \_\_\_\_\_ Site conditions\*: \_\_\_\_\_  
*\*(Stable, Under Construction, Needing Maintenance, etc.)*

Date	Initials	Depth of Floatables and Oils Removed	Sediment Depth Measured Prior to Removal	Site Activity and Comments

\*Note: Sediment removal is not required unless sediment depths exceed 75% of maximum clean-out depths stated in Table 1.

### Notes

---



---



---





## Downstream Defender® Inspection Log

Site Name: \_\_\_\_\_ Owner Change since last inspection? Y N

Location: \_\_\_\_\_

Owner Name: \_\_\_\_\_

Address: \_\_\_\_\_ Phone Number: \_\_\_\_\_

Site Status: \_\_\_\_\_

Date: \_\_\_\_\_ Time: \_\_\_\_\_ Site conditions\*: \_\_\_\_\_  
 \*(Stable, Under Construction, Needing Maintenance, etc.)

Inspection Frequency Key: A=annual; M=monthly; S=after major storms

Inspection Items	Inspection Frequency	Inspected? (Yes/No)	Maintenance Needed? (Yes/No)	Comments/Description
<b>Debris Removal</b>				
Adjacent area free of debris?	M			
Inlets and Outlets free of debris?	M			
Chamber free of debris?	M			
<b>Vegetation</b>				
Surrounding area fully stabilized? (no evidence of eroding material in Downstream Defender®)	A			
Grass mowed?	M			
<b>Water retention where required</b>				
Water holding chamber(s) at normal pool?	M			
Evidence of erosion?	A			
<b>Sediment Deposition</b>				
Sedimentation sump not more than 50% full?	A			
<b>Structural Components</b>				
Any evidence of structural deterioration?	A			
Rim & cover in good condition?	A			
Spalling or cracking of structural parts?	A			
Outlet/Overflow Spillway	A			
<b>Other</b>				
Noticeable odors?	A			
Evidence of flow bypassing facility?	A			







# Hydro International Certification Program

## for Stormwater BMP Maintenance Providers

The Hydro International Stormwater BMP Maintenance Certification verifies that a stormwater BMP maintenance provider has been trained on the proper inspection and maintenance procedures for Hydro International's manufactured stormwater treatment products.

Maintenance providers who complete this complimentary web-based program become a Hydro International Preferred Stormwater BMP Maintenance Partner. Become a Hydro International certified Stormwater BMP maintenance provider today.

Learn more at <http://www.hydro-int.com/us/products/service-parts>



## Stormwater Solutions

94 Hutchins Drive  
Portland, ME 04102

Tel: (207) 756-6200  
Fax: (207) 756-6212  
[stormwaterinquiry@hydro-int.com](mailto:stormwaterinquiry@hydro-int.com)

[www.hydro-int.com](http://www.hydro-int.com)

Turning Water Around...®

©Hydro International DD\_O+M\_D1304